



Sirius

SM/SL 927

52 CM (SL92752)

85 CM (SL92785)

Motor: on board

Lighting:

1x6,5W Led strip (SM927 52cm version)

1x10,5W Led strip (SM927 85cm version)

Control panel:

4 speeds push-button+light switch

Filter:

Anodized aluminum (5+1layers)

Material: Painted stainless steel and glass panel



Showroom: Av. Álvarez Thomas 636, CABA
www.kalitekno.com | @kalitekno



Sirius

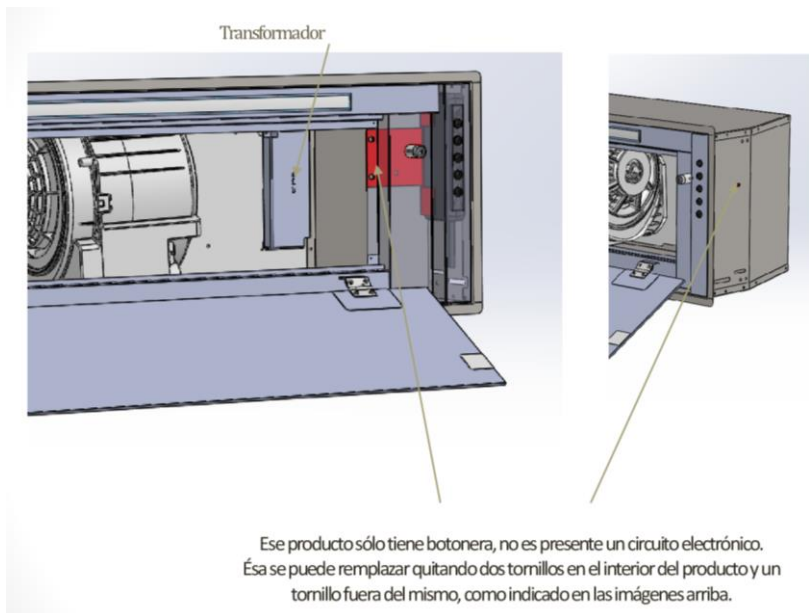
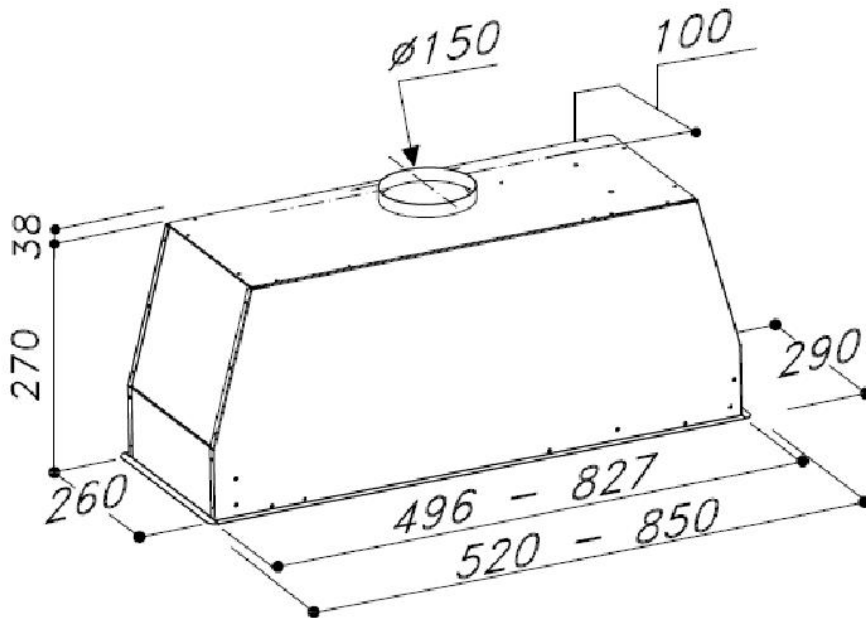

Showroom: Av. Álvarez Thomas 636, CABA
www.kalitekno.com | @kalitekno